

L.v. BEETHOVEN



W.A. MOZART



NOTENHEFT

F. SCHUBERT



J. HAYDN



J. STRAUSS



FORNAT

Sextett für

Flöte - Oboe - Klarinette -
Horn - Fagott und Klavier
1975 (Tonband)

- Teil 1 = Prestissimo
- Teil 2 = Lento
- Teil 3 = Prestissimo
- Teil 4 = sehr breit - Prestissimo

Lautsprecher-
im Saal verteilt -
(teilweise mit Hall)
Verstärkeranlage:

Teil 1 (Teil 3)

Prestissimo

Solo

2/4

ppp

Block A

Klavier

6 Takte nachher (Block A)

Block A

58 59 60

Block A

Block A

Block A

Block A

61 62 63 64

Langsam Halt einblenden →
immer mehr →

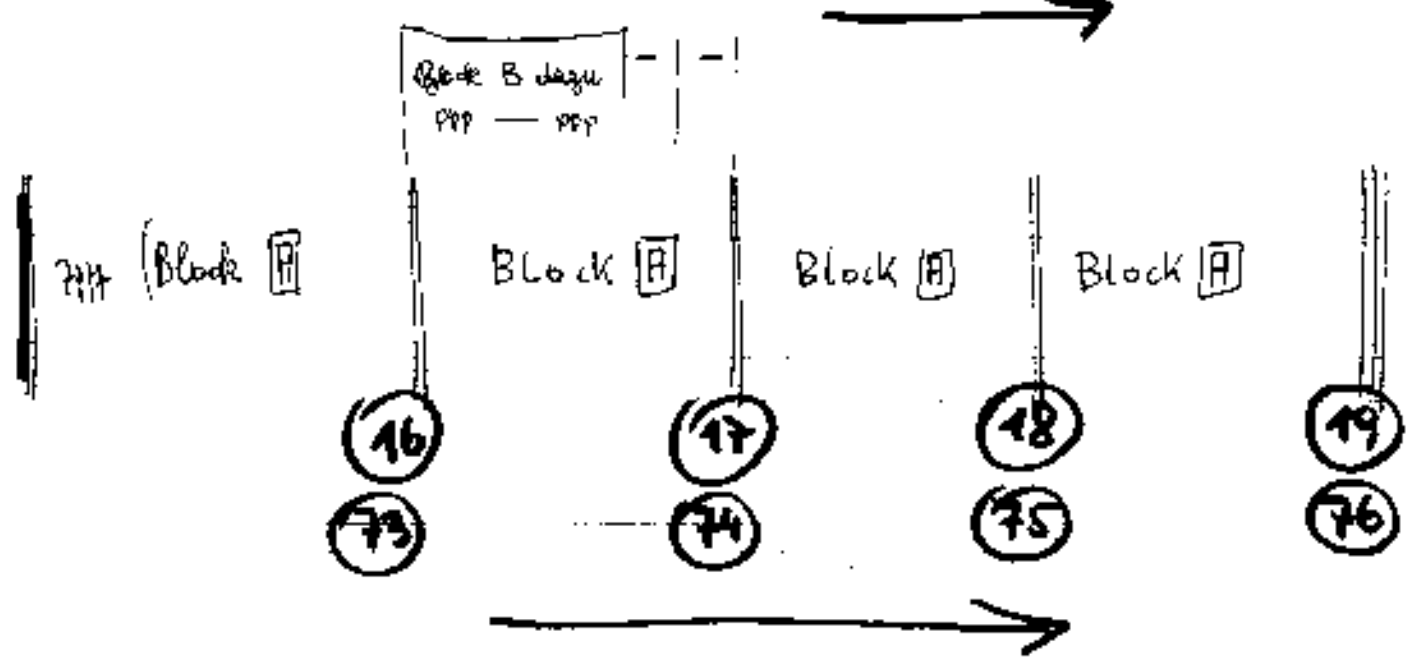
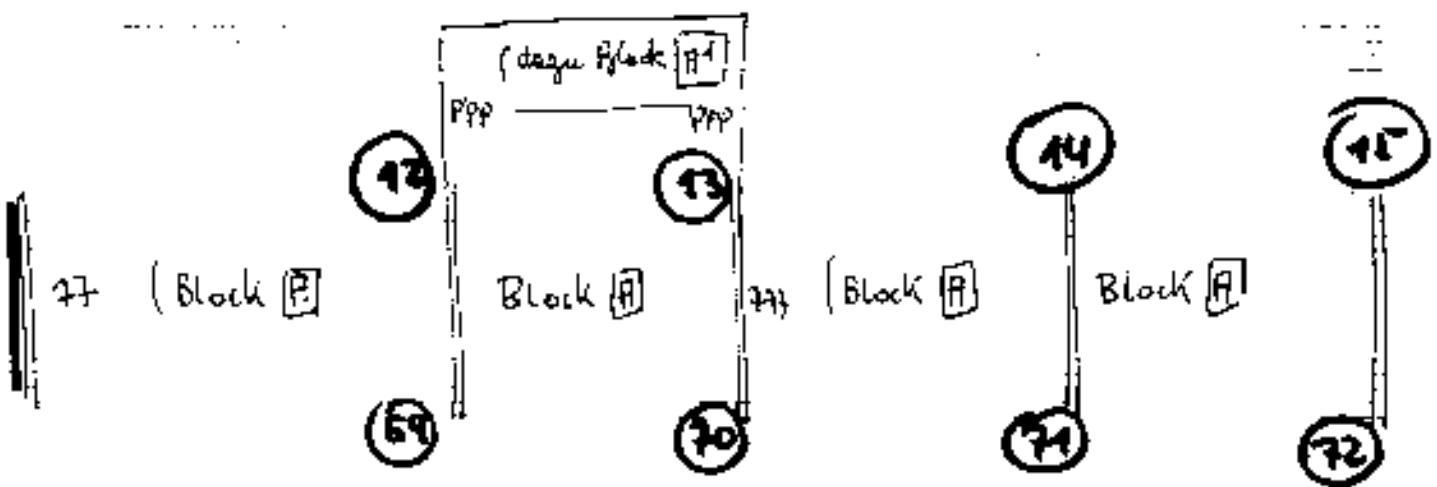
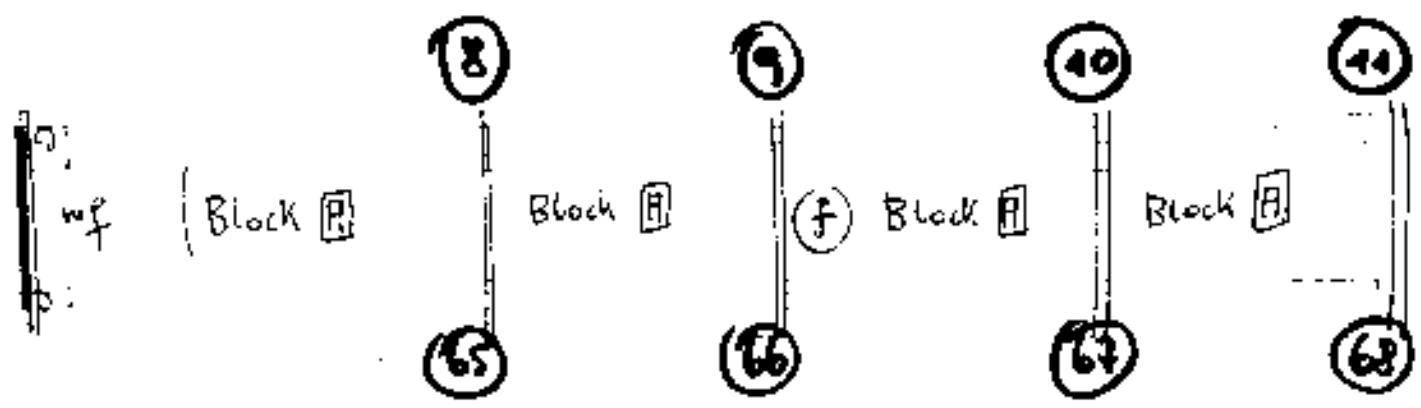

Handwritten musical score on page 20 (circled in the top right corner). The score is written on a grand staff with five systems of staves. The instruments are labeled on the left as Fl. (Flute), Ob. (Oboe), Klar. (Clarinet), Horn, and Klarier (Clarinete). A large arrow at the top left points to the first system and is labeled "ziel H₂O →". The notation includes various notes, rests, and dynamic markings such as "inc" and "b". A bracket at the bottom of the score spans the first two systems and is labeled "daszu Block [A] = Block [A¹]".

Handwritten musical score on page 21 (circled in the top right corner). The score is written on a grand staff with five systems of staves. The first system is labeled "Solo (Klavier)" and is enclosed in a large bracket. Below the first system, the text "Block [A]" is written. The rest of the page contains empty musical staves.

Hall zurück ←

22 (A)

Handwritten notes on the left margin, possibly indicating fingerings or positions.

Solo (Klavier)

Block (A)

Hall — wieder aufstecken →

23
30

Hall

24
81

Handwritten musical score for system 24, measures 81-85. The system consists of five staves. The first staff has a treble clef and a key signature of one sharp (F#). It begins with a dynamic marking of *pp* and contains several notes with stems. Above the first two measures, there are markings for a 4-measure phrase. The second staff also starts with *pp* and contains notes. The third staff has a dynamic marking of *pp* and notes. The fourth staff has a dynamic marking of *mf* and notes. The fifth staff has a dynamic marking of *mf* and notes. The system concludes with a double bar line.

25
82

Handwritten musical score for system 25, measures 82-86. The system consists of five staves. The first staff has a treble clef and a key signature of one sharp (F#). It begins with a dynamic marking of *ppp* and contains notes with stems. The second staff has a dynamic marking of *ppp* and notes. The third staff has a dynamic marking of *ppp* and notes. The fourth staff has a dynamic marking of *pp* and notes. The fifth staff has a dynamic marking of *ppp* and notes. The system concludes with a double bar line.

- Hall way -

Solo

Handwritten musical notation for a solo section. It features a treble clef staff with notes marked with accents (^) and a bass clef staff with a triplet of eighth notes. The notes in the treble staff are: #, b, b, #, #, b, b, #, #, #, #. The bass staff shows a triplet of eighth notes in the first measure, followed by rests. A circled number '26' is in the top right corner, and a circled number '83' is in the middle right corner.

Handwritten musical notation for a section labeled "Block B". It consists of three staves with triplets of eighth notes. The notes are: Staff 1: #, b, #, #, b, #; Staff 2: #, b, b, #, #, #; Staff 3: #, b, #, #, b, #. A circled number '27' is in the top right corner, and a circled number '84' is in the middle right corner.

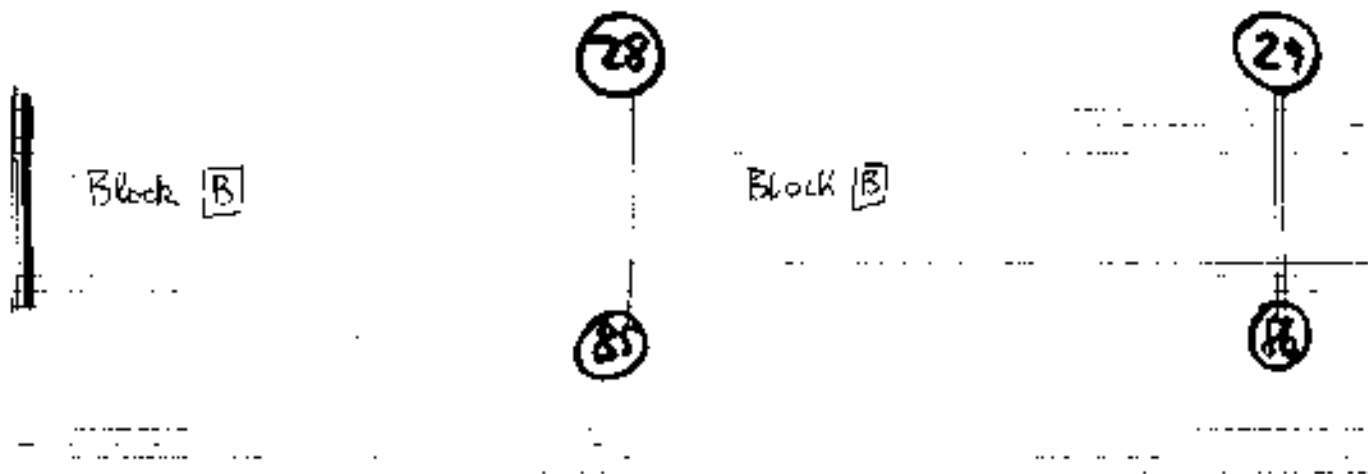

Block B

Flatterzunge

con sord.

77

77a

77b

77c

30

87

Solo

Handwritten musical score for system 31. It features a treble clef with a key signature of one sharp (F#) and a common time signature. The melody consists of quarter notes with accents, grouped by slurs. The bass line shows a sequence of chords with a '4' indicating a four-measure rest. A circled '31' is in the top right, and a circled '88' is in the middle right.

Handwritten musical score for system 32. It features a treble clef with a key signature of one sharp (F#) and a common time signature. The melody consists of quarter notes with accents, grouped by slurs. The bass line shows a sequence of chords with a '4' indicating a four-measure rest. A circled '32' is in the top right, and a circled '89' is in the middle right.

Handwritten musical score for system 33. It features a treble clef with a key signature of one sharp (F#) and a common time signature. The melody consists of quarter notes with accents, grouped by slurs. The bass line shows a sequence of chords with a '4' indicating a four-measure rest. A circled '33' is in the top right, and a circled '90' is in the middle right.

85

92

The image shows a handwritten musical score for guitar and bass. The guitar part is written on six staves, with a large bracket on the left side. The first two staves contain chord diagrams with accidentals (flats and naturals). The next four staves contain melodic lines with notes and accidentals. The bass part is written on two staves. The top staff of the bass part is labeled 'Solo' and contains rhythmic notation with flags. The bottom staff of the bass part contains a bass line with notes and accidentals. The score is divided into measures by vertical dashed lines.

(hant)

12

36

13

Handwritten musical score for a piano piece, measures 36-39. The score consists of six staves. The first five staves are grouped by a large bracket on the left. The first staff has a treble clef and a key signature of one flat (B-flat). The second staff has a bass clef. The third, fourth, and fifth staves have a treble clef. The sixth staff has a bass clef. The music is written in a sketchy, handwritten style with various notes, stems, and accidentals. The first two measures of each staff contain the main melodic and harmonic material, while the last two measures are mostly rests or simple accompaniment.

35

34

Handwritten musical score for guitar, page 34. The score is written on six staves. The first two staves are for the right hand, and the last four are for the left hand. The music features a wavy, tremolo-like pattern in the right hand and a series of chords in the left hand. The chords are marked with 'x' and are grouped by brackets. There are various musical notations including accidentals (sharps, naturals), stems, and beams. A large bracket on the left side groups the first four staves. At the bottom left, there are additional handwritten notes and diagrams, including a diagram of a guitar fretboard with notes and a diagram of a guitar body with notes.

38

95

Handwritten musical score for a string quartet, measures 38-42. The score includes staves for Violin I, Violin II, Viola, and Cello/Double Bass. It features dynamic markings like *pp*, *f*, and accents, as well as articulation marks and triplet notations.

Solo

(Block A)

(Block A)

39

40

36

37

ffp

ffp

41

38

ffp

Teil 2

Klavier: Solo (mit Hall)

Handwritten musical notation for the first system, featuring a treble clef, a key signature of one sharp (F#), and a 4/8 time signature. The notation includes a piano (p) dynamic marking, a forte (f) dynamic marking, and a slur over a series of notes. A handwritten '(2x)' is written above the first measure.

Handwritten musical notation for the second system, featuring a treble clef and a key signature of one sharp (F#). The notation includes a piano (pp) dynamic marking, a forte (f) dynamic marking, and a slur over a series of notes. A handwritten '>fp' is written below the final measure.

Handwritten musical notation for the third system, featuring a treble clef and a key signature of one sharp (F#). The notation includes a piano (pp) dynamic marking, a piano (p) dynamic marking, and a slur over a series of notes. A handwritten 'steigern' is written above the second measure.

Handwritten musical notation for the fourth system, featuring a treble clef and a key signature of one sharp (F#). The notation includes a piano (p) dynamic marking, a forte (f) dynamic marking, and a slur over a series of notes. A handwritten 'accel.' is written above the first measure, and a handwritten 'zuerst' is written above the second measure.

Halt zurück ←

ait... dän...

42

Musical notation for measures 16 and 17. Measure 16 features a bass clef and a flat sign. Measure 17 features a treble clef and a sharp sign. Dynamics include > p and > pp. The word 'lunga' is written above the notes.

Lento (♩) Halte

Detailed musical score for measures 18 and 19. The score includes multiple staves with notes, rests, and dynamics such as pp. Accents are placed over various notes. A large bracket on the left side groups the first four staves.

43

Hand zurück ←

44

Stacc.

quadr.

45

breit Solo

46

sehr breit

47

47

immer paroler werden →



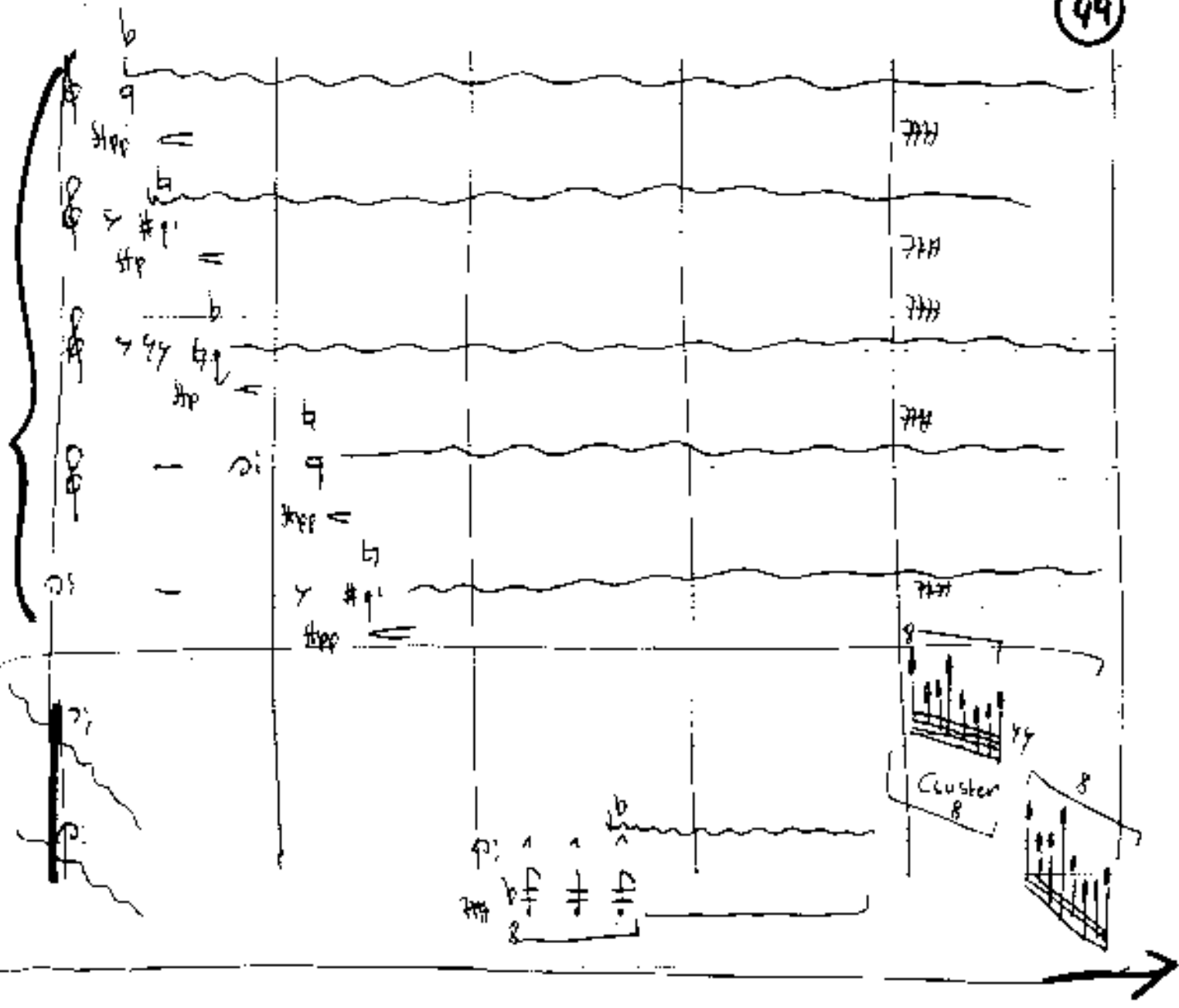

selo nandi and ewegit

50

51

Handwritten musical score for a string quartet. The score is written on five staves: two violins (top two), two violas (middle two), and a cello (bottom). The music is in treble clef with a key signature of one sharp (F#). The first violin part has a large '2' written next to it. The score is divided into two systems, each labeled 'Block' with a circled 'E'.

Block E

Block E

Part 2 ↑

harpes staccato

The image shows a handwritten musical score for harp, titled "harpes staccato". The score is written on a set of five staves. The first two staves contain melodic lines with notes and stems, marked with fingerings (5, 6) and accents (^). The next two staves contain chords, also marked with fingerings and accents. The fifth staff contains a bass line with notes and stems. Below the first five staves, there are two staves of chords, one in treble clef and one in bass clef, both marked with accents. The right side of the page shows a series of empty staves with some arrows and brackets, possibly indicating fingerings or articulation for the chords. A circled number "51" is in the top right corner.

moda auel...

The image shows a handwritten musical score for guitar, organized into six horizontal staves. The notation includes rhythmic markings such as brackets and arrows, and chord diagrams. The first two staves on the left are grouped by a large bracket. The bottom staves contain specific chord diagrams, including a G major chord with a sharp sign, a C major chord with a sharp sign, and a C major chord with a natural sign. The right side of the page features two guitar neck diagrams with fret numbers and chord symbols. The entire score is enclosed in a hand-drawn rectangular border.

Flöte (Pär) H. 2

Handwritten musical notation for Flöte (Pär) H. 2, first system. It shows a treble clef, a 4/8 time signature, and a key signature of one sharp (F#). The notation includes a series of notes with a slur and an accent (>) above it. A bracket below the notes is labeled "scubato".

Handwritten musical notation for Flöte (Pär) H. 2, second system. It continues the piece with notes, slurs, and accents. A bracket below the notes is labeled "ranch - aca".

Handwritten musical notation for Flöte (Pär) H. 2, third system. It features notes with slurs and accents. A bracket below the notes is labeled "Presto (Flatter)".

Handwritten musical notation for Flöte (Pär) H. 2, fourth system. It shows a continuation of the melodic line with slurs and accents.

Handwritten musical notation for Flöte (Pär) H. 2, fifth system. It includes the word "Lento" above the notes, "pp" below, and "rit dim" below. The system ends with a circled number "54".

solos pulip (mysterioso) **ohne Hall.**

Solo

4/8 pp

rit....

55

Leute (B) (Haut —)

56

Handwritten musical score for a solo section. The score is written on a five-line staff with various musical notations including notes, rests, and dynamic markings. A large bracket on the left side groups the first four measures. A large 'B' is written on the left side of the staff. The word 'SOLO' is written in bold letters in the middle of the staff. Below the staff, there are handwritten notes: 'Piedal' in a box, an upward-pointing arrow labeled '(paci)', and 'Piedal' again. The notes 'Piedal' and '(paci)' are written in a stylized, possibly non-standard, script. The notes 'Piedal' and '(paci)' are written in a stylized, possibly non-standard, script.

Klaviersette (Solo) frei (über Hall (Lautsprecher) im Saal)

pp # $\frac{4}{8}$ $\hat{F} \hat{G} \hat{A} \hat{B} \hat{C}$

pp $\hat{G} \hat{F} \hat{E} \hat{D} \hat{C}$

pp $\hat{C} \hat{D} \hat{E} \hat{F} \hat{G}$

pppp $\hat{G} \hat{A} \hat{B} \hat{C}$

gr. rit - stän... ..

lange

57

folgt Teil 1 = Teil 3

Teil 4

suber breit

Handwritten musical score for the left page of 'Teil 4'. It features six staves. The top five staves contain melodic lines with various accidentals (sharps, flats, naturals) and are grouped by a large bracket on the left. The bottom staff is labeled 'Solo' and contains two rectangular boxes, one of which is labeled 'CLUSTER'. The music is written in a system with two measures per staff.

Handwritten musical score for the right page of 'Teil 4'. It features six staves. The top five staves contain melodic lines with various accidentals and are grouped by a large bracket on the left. The bottom staff contains two rectangular boxes. A circled number '1' is in the top right corner. The music is written in a system with two measures per staff.

Handwritten musical score for a string quartet, consisting of five staves. The notation includes various musical symbols such as clefs, accidentals, and stems. A large bracket on the left side groups the first four staves together. The bottom staff contains rhythmic markings, possibly indicating bowing or fingerings.

Prestissimo 4

SOLO

$\frac{2}{4}$ *ppp*

Block **D** rampa cresc.

③

④

Block **D** Block **D** Block **D** Block **D**

⑤ ⑥ ⑦

⑧ ⑨ ⑩ ⑪

⑧ *pp* Block **D** Block **D** Block **D** Block **D**

Halt langsam - aufdrehen → immer mehr →

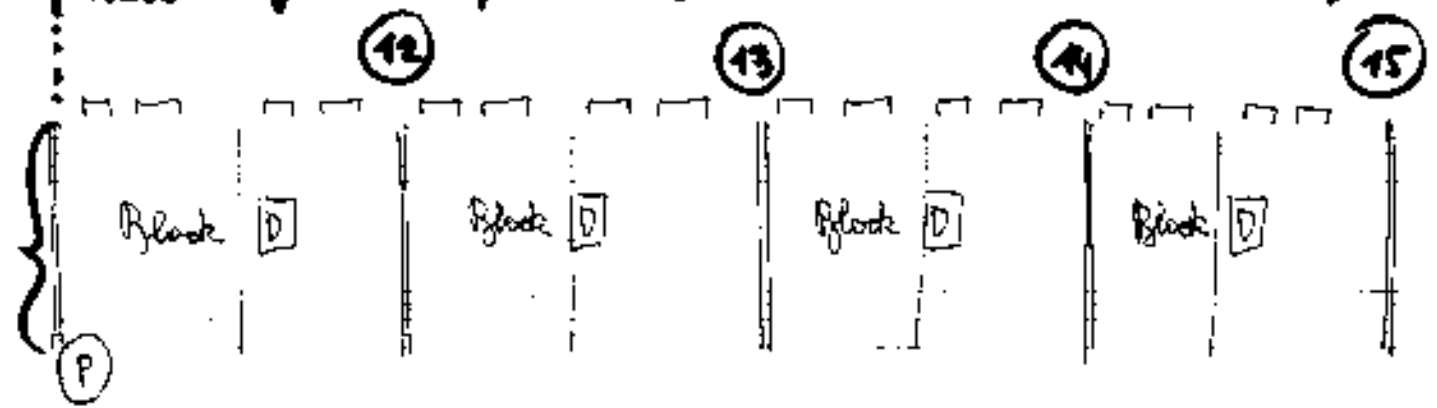

→

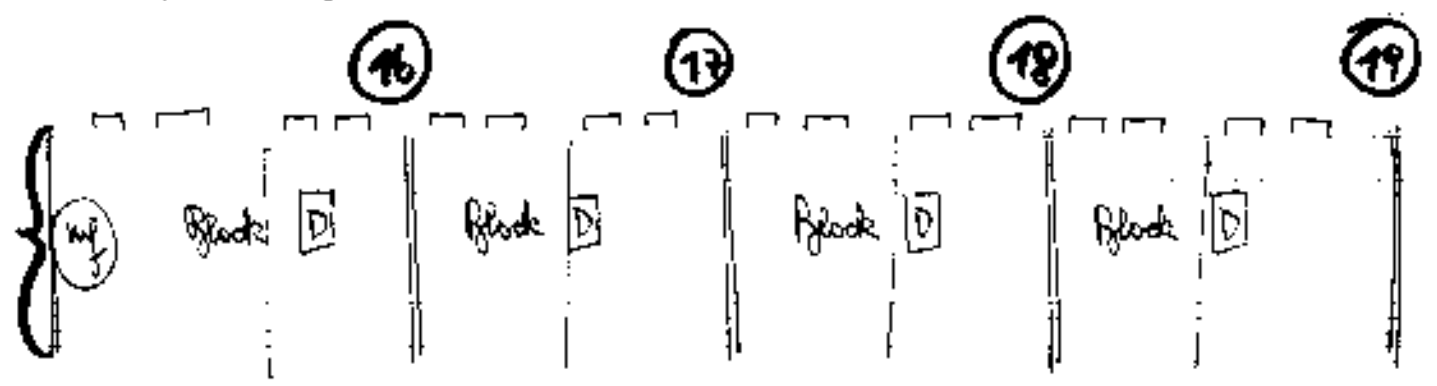

→ bis [27] III

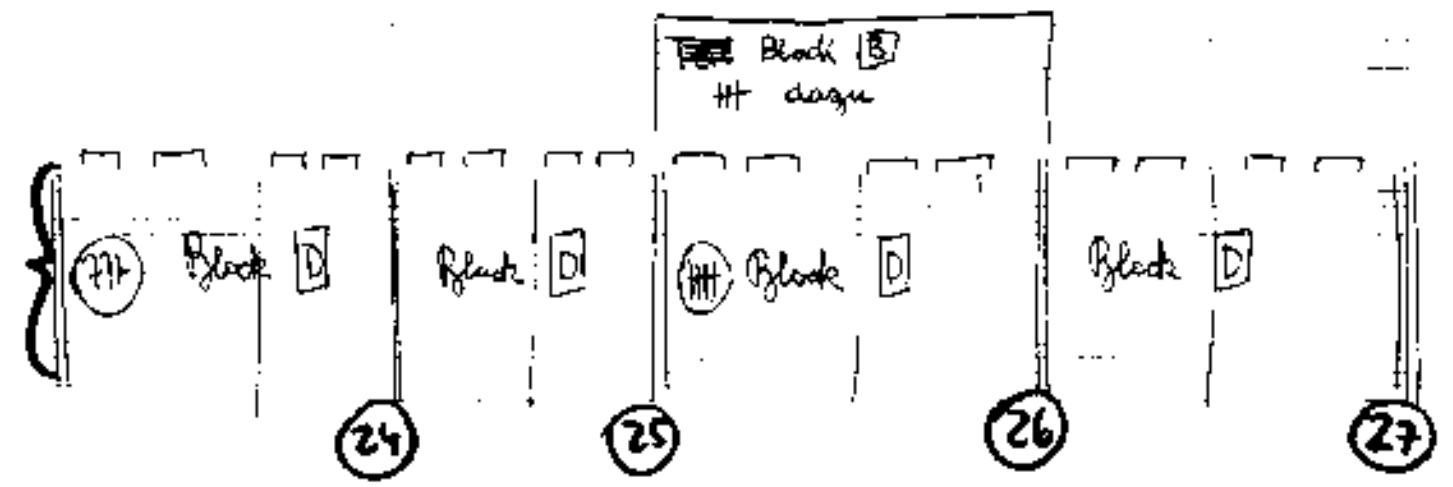
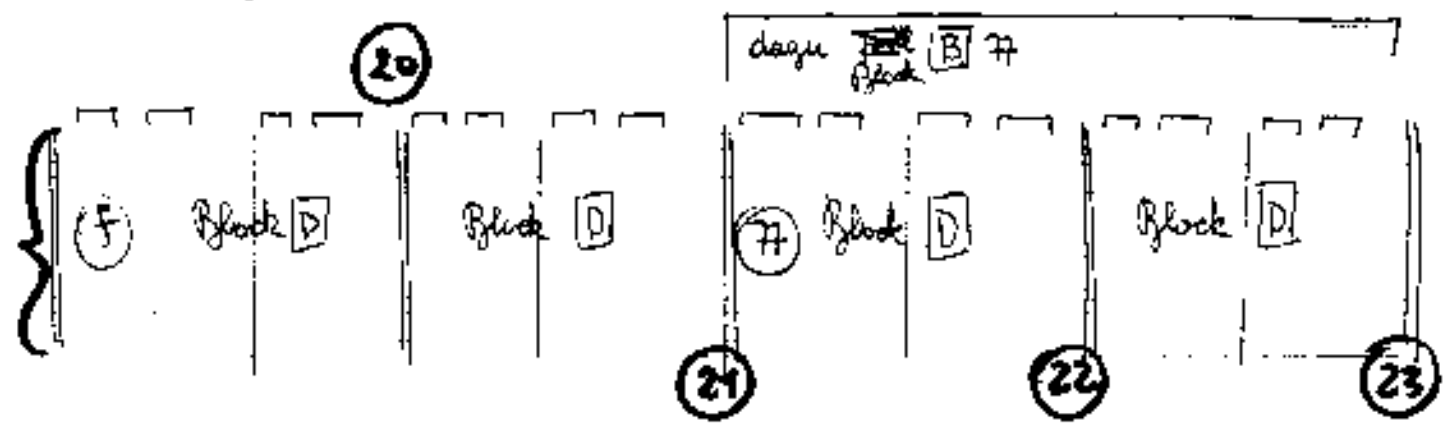

Handwritten musical score for page 34, measures 1-4. The score is written on a grand staff with five staves. The first staff is a treble clef with a key signature of one sharp (F#). The second staff is a bass clef with a key signature of one sharp (F#). The third, fourth, and fifth staves are also treble clefs with a key signature of one sharp (F#). The notation includes chords, melodic lines, and dynamic markings like 'p' and 'f'.

Handwritten musical score for page 34, measures 5-8. The score is written on a grand staff with five staves. The first staff is a treble clef with a key signature of one sharp (F#). The second staff is a bass clef with a key signature of one sharp (F#). The third, fourth, and fifth staves are also treble clefs with a key signature of one sharp (F#). The notation includes chords, melodic lines, and dynamic markings like 'p' and 'f'.

28

Handwritten musical notation for page 35, top section. It features a grand staff with four systems of music. The first system is a treble clef with a key signature of one flat (Bb). The second system is a bass clef with a key signature of one flat (Bb). The third system is a treble clef with a key signature of one flat (Bb). The fourth system is a bass clef with a key signature of one flat (Bb). The notation includes various chords, intervals, and melodic lines with slurs and accents.

Handwritten musical notation for page 35, bottom section. It features a grand staff with four systems of music. The first system is a treble clef with a key signature of one flat (Bb). The second system is a bass clef with a key signature of one flat (Bb). The third system is a treble clef with a key signature of one flat (Bb). The fourth system is a bass clef with a key signature of one flat (Bb). The notation includes various chords, intervals, and melodic lines with slurs and accents.

29

Solo

Handwritten musical notation for system 31. The system consists of two staves: a treble clef staff and a bass clef staff. The treble staff contains a melodic line with notes, rests, and accents (^). The bass staff contains a bass line with notes and rests. The system is divided into four measures. The first two measures have a circled number '31' at the end. The second measure has a circled '31' at the end. The third measure has a circled '31' at the end. The fourth measure has a circled '31' at the end.

Handwritten musical notation for system 32. The system consists of two staves: a treble clef staff and a bass clef staff. The treble staff contains a melodic line with notes, rests, and accents (^). The bass staff contains a bass line with notes and rests. The system is divided into four measures. The first measure has a circled number '32' at the end. The second measure has a circled '32' at the end. The third measure has a circled '32' at the end. The fourth measure has a circled '32' at the end.

Handwritten musical notation for system 33 and 34. The system consists of two staves: a treble clef staff and a bass clef staff. The treble staff contains a melodic line with notes, rests, and accents (^). The bass staff contains a bass line with notes and rests. The system is divided into four measures. The first measure has a circled number '33' at the end. The second measure has a circled '33' at the end. The third measure has a circled '33' at the end. The fourth measure has a circled '34' at the end. Above the treble staff, there is a circled '33' and the text 'dazu Block' with a circled '33' and a circled '34'.

Handwritten musical score for a string quartet, page 38. The score is divided into two systems. The first system consists of five staves, with the first four grouped by a brace and marked 'pp'. The second system consists of two staves, with the first marked 'pp' and 'Solo'. The notation includes various chords, intervals, and melodic lines with slurs and accents.

The image shows a handwritten musical score for guitar, divided into three measures. The top part of the page contains a guitar part with a large bracket on the left side, indicating a specific section. The bottom part contains a bass part, also with a large bracket. The score is written on a grid of five-line staves. The notation includes various chord diagrams, melodic lines with accidentals, and dynamic markings such as 'f' (forte) and 'p' (piano). The key signature appears to be one sharp (F#) and one flat (Bb). The first measure shows a series of chords and a melodic line. The second measure continues with similar notation. The third measure concludes the section with a final chord and melodic line. The page is numbered '35' in a circle in the top right corner.

Block E



Block E

27

Handwritten musical notation for Block E, consisting of five staves. The notation includes various notes, accidentals (sharps, flats, naturals), and brackets. The first staff has a circled number 37. The notation is organized into groups of two staves each, with a large bracket on the left side encompassing all five staves.

Block F

Solo

Block **D**

Block **F**

Block **D**

Block **F**

Block **D**

Block **F**

subito

(mit Geschwindigkeit 14) abgepielt über Lautsprecher.
 mit Geschwindigkeit (9½ oder 4⁷⁵)

fieri (wird auf Tonband aufgenommen) und

editio (siehe Kap. 10) (Tonband)

ppp **Tonband**

ffff (♩)

ppp G# A

ppp

ppp G# A

dazu (live) mehr stark und Prestissimo!
 (od. lib.) immer in Abständen
 ff (F) m

Handwritten musical notation on page 43. The notation is written on a grand staff with five staves. The first four staves are grouped by a brace on the left and contain multi-measure rests. The fifth staff contains a melodic line starting with a circled 'c' and a treble clef. The notes are: C4, D4, E4, F#4, G4, A4, B4, C5. The piece ends with a double bar line.

44

Handwritten musical notation on page 44. The notation is written on a grand staff with five staves. The first four staves are grouped by a brace on the left and contain multi-measure rests. The fifth staff contains a melodic line starting with a treble clef and a circled 'c'. The notes are: C4, D4, E4, F#4, G4, A4, B4, C5. The piece ends with a double bar line.

Handwritten musical score for a string quartet. The score is written on five staves. The first four staves are grouped by a large bracket on the left. The notation includes notes, rests, and dynamic markings such as *pp* and *ppp*. A large, wavy line at the bottom of the page is labeled "Solo" and "Padai". The text "Tonband ausblenden" is written at the bottom right. A circled number "45" is in the top right corner.

F in das Tonband (per se Schluss schon beginnen) (ppp $\frac{2}{4}$ Prestissimo)

Prestissimo

51

ppp *solo*

sempre cresc.

Block D

46

Block D

47

Block D

48

Block D

49

Block D

50

pp

Block D

51

Block D

52

Block D

53

Block D

54

↑
Tonband einblenden (ppp ← ganz leise und immer mehr aufsteigend →)

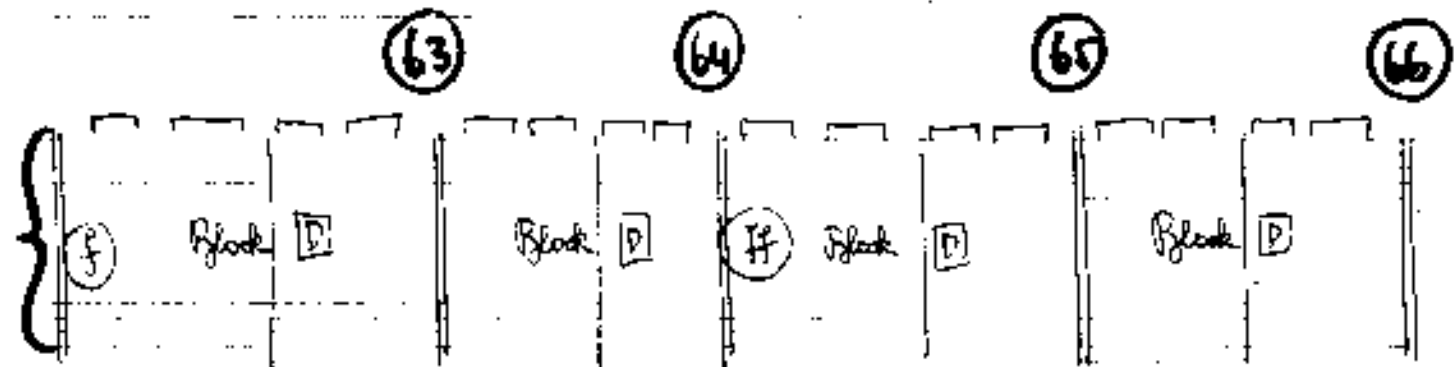
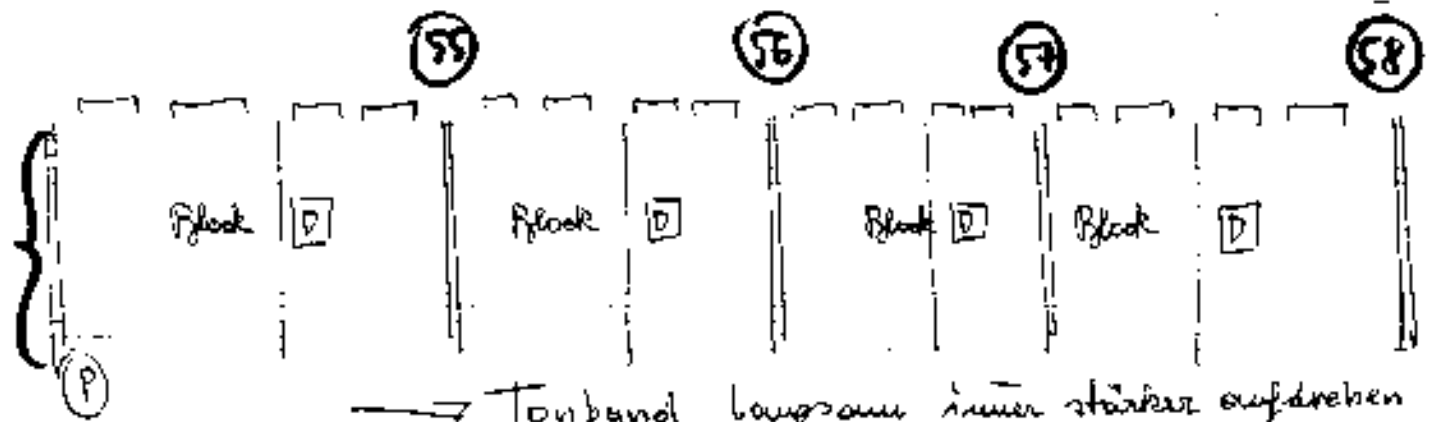

67

68

69

70

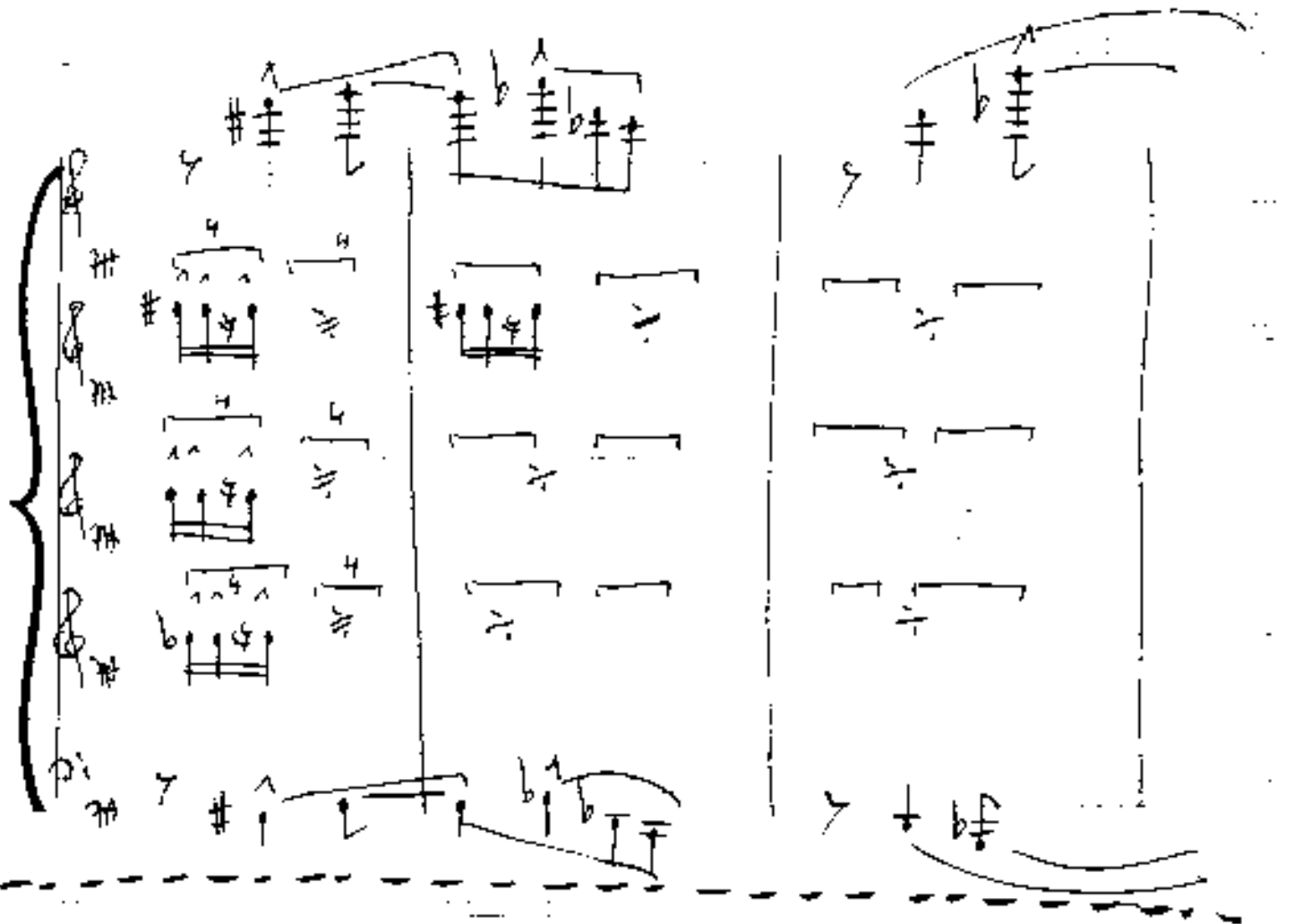
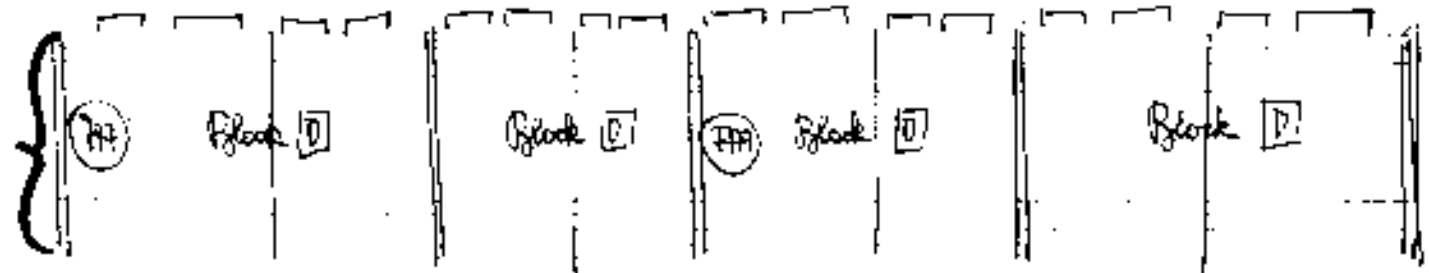

Handwritten musical notation for page 71, featuring a grand staff with four staves and a bass line. The notation includes various chords, melodic lines, and dynamic markings.

Staff 1 (Soprano): Chords: b (B-flat), $\#$ (sharp), b (B-flat), $\#$ (sharp).

Staff 2 (Alto): Chords: b (B-flat), $\#$ (sharp).

Staff 3 (Tenor): Chords: b (B-flat), $\#$ (sharp).

Staff 4 (Bass): Chords: b (B-flat), $\#$ (sharp).

Bass Line: Chords: $\#$ (sharp), b (B-flat), $\#$ (sharp).

Page number: 71

Handwritten musical notation for page 72, featuring a grand staff with four staves and a bass line. The notation includes various chords, melodic lines, and dynamic markings.

Staff 1 (Soprano): Chords: b (B-flat), $\#$ (sharp), b (B-flat).

Staff 2 (Alto): Chords: b (B-flat), $\#$ (sharp).

Staff 3 (Tenor): Chords: b (B-flat), $\#$ (sharp).

Staff 4 (Bass): Chords: b (B-flat), $\#$ (sharp).

Bass Line: Chords: $\#$ (sharp), b (B-flat).

Page number: 72

Handwritten musical score for a band, numbered 72. The score is written on a grand staff with four staves (two treble clefs and two bass clefs) and a separate bass line. The notation includes chords, melodic lines, and dynamic markings. A circled number '72' is in the top right. The text 'Tonband aus.' is written at the bottom right.

Solo

Handwritten musical score for a solo, numbered 73. The score is written on a grand staff with two staves (treble and bass clefs) and a separate bass line. The notation includes chords, melodic lines, and dynamic markings. A circled number '73' is in the top right.

75

76

77

78

(claque (77) Block [C])

Over... →

79

pp

pp

pp

pp

pp

pp=

Solo

Block

Handwritten musical score for guitar, page 80. The score is written on five staves. The first four staves are grouped by a large left-facing curly brace. The fifth staff is grouped by a right-facing curly brace. The music includes various chord diagrams with accidentals (sharps, flats, naturals) and stems. There are also some handwritten annotations like 'f' and arrows. The bottom of the page shows empty staves.

77

Block E ←

777

Handwritten musical score for guitar, consisting of six staves. The score is divided into two sections: the first section is labeled "Block E" with a square symbol and an arrow pointing left, and the second section is also labeled "Block E" with a square symbol. The notation includes various chords and melodic lines with accidentals (sharps and flats). A circled number "82" is in the top right corner of the score area.

Solo

Block **D**

83

Block **F**

84

85

Block **D**

Block **F**

86

87

88

ppp Block [D] ppp Block [F]

89

Solo

Handwritten musical score for guitar, consisting of six staves. The first five staves are grouped by a large bracket on the left. The notation includes various chords, accidentals (sharps, flats), and slurs. The sixth staff features a diagram of a guitar fretboard with notes marked. Below the sixth staff, there are two large oval shapes, each with a chord diagram above it. The notation is dense and appears to be a personal or working manuscript.

This page contains a handwritten musical score for guitar, consisting of several staves. The notation includes various chord symbols, such as triads and dyads, often with accidentals (sharps and naturals) and dynamic markings like accents (>) and slurs. The score is organized into measures, with some measures containing multiple chords. A large bracket on the left side groups several measures together. At the bottom of the page, there are two large, hand-drawn shapes that resemble stylized guitar bodies or abstract musical forms, each containing chord symbols and accidentals. The overall style is that of a personal practice or teaching manuscript.

Handwritten musical notation on a staff, featuring a large bracket on the left side. The notation includes notes with sharp signs and stems.

Handwritten musical notation on a staff, showing notes with sharp signs and stems.

Handwritten musical notation on a staff, showing notes with sharp signs and stems.

Handwritten musical notation on a staff, showing notes with sharp signs and stems.

Handwritten signature
 Aug 1975